

**General Instructions:**

1. The question paper comprises **two** Sections, **A and B**. You are to attempt both the sections.
2. All questions are **compulsory**.
3. There is no choice in any of the questions.
4. All questions of **Section A** and all questions of **Section B** are to be attempted separately.
5. Question numbers **1 to 3** in Section A are one-mark questions. These are to be answered in one word or in one sentence.
6. Question numbers **4 to 6** in Section A are two-mark questions. These are to be answered in about 30 words each.
7. Question numbers **7 to 18** in Section A are three-mark questions. These are to be answered in about 50 words each.
8. Question numbers **19 to 24** in Section A are five-mark questions. These are to be answered in about 70 words each.
9. Question numbers **25 to 33** in Section B are multiple choice questions based on practical skills. Each question is a one-mark question. You are to select one most appropriate response out of the four provided to you.
10. Question numbers **34 to 36** in Section B are two-marks questions based on practical skills. These are to be answered in brief.

**SECTION A**

**Question 1.** Write the name and structure of an aldehyde with four carbon atoms in its molecule.

**Solution:** 1-butanal

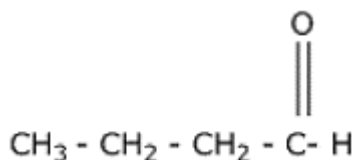

**Marks: 1**

**Question 2.** List two functions ovary of human female reproductive system.

**Solution:** Two functions of the ovaries of the human female reproductive system are

1. To produce ova, which are female gametes
2. To secrete the female hormones oestrogen and progesterone.

**Marks: 1**

**Question 3.** In a food chain of frog, grass, insect and snake, assign trophic level to frog.

**Solution:** Grass  $\longrightarrow$  Insect  $\longrightarrow$  Frog  $\longrightarrow$  Snake

Frog is a secondary consumer.

**Marks: 1**

**Question 4.** The refractive indices of glass and water with respect to air are  $\frac{3}{2}$  and  $\frac{4}{3}$  respectively. If speed of light in glass is  $2 \times 10^8$  m/s, find the speed of light in water.

**Solution:** Given:  $n_g = \frac{3}{2}$  and  $n_w = \frac{4}{3}$

$$\text{Refractive index of glass, } n_g = \frac{\text{Speed of light in air}}{\text{Speed of light in glass}}$$

$$\frac{3}{2} = \frac{\text{Speed of light in air}}{2 \times 10^8}$$

$$\therefore \text{Speed of light in air} = \frac{3}{2} \times 2 \times 10^8 = 3 \times 10^8 \text{ m/s}$$

∴ Thus, the speed of light in air is  $3 \times 10^8$  m/s.

**Marks: 2**

**Question 5.** List four stakeholders which may be helpful in the conservation of forests.

**Solution:** Four stakeholders which may help in the conservation of forests are

1. The Forest Department of the Government which owns the forest land and controls the resources from forests
2. People who live in and around the forest and are dependent on forest produce to lead their lives
3. Industrialists who use various forest products for their factories
4. Forest and wildlife activists who want to see forests in their original form.

**Marks: 2**

**Question 6.** The construction of large dams leads to social and environmental problems. List two problems of each category.

**Solution:** Social problems arise because the construction of dams causes the displacement of a large number of tribals and peasants who are then rendered homeless. They are neither given sufficient compensation or rehabilitation nor do they get any benefits from these projects.

Construction of dams leads to several environmental problems such as deforestation and loss of biodiversity because large areas of forest land get submerged in water leading to an ecological imbalance.

**Marks: 2**

**Question 7.** The position of eight elements in the Modern Periodic Table is given below where atomic numbers of elements are given in the parenthesis.

Period No.		
2	Li(3)	Be(4)
3	Na(11)	Mg(12)
4	K(19)	Ca(20)
5	Rb(37)	Sr(38)

- (i) Write the electronic configuration of Ca.
- (ii) Predict the number of valence electrons in Rb.
- (iii) What is the number of shells in Sr?
- (iv) Predict whether K is a metal or a non-metal.
- (v) Which one of these elements has the largest atom in size?
- (vi) Arrange Be, Ca, Mg and Rb in the increasing order of the size of their respective atoms.

**Solution:** (i) Electronic configuration of Ca (20): 2, 8, 8, 2

(ii) Rb belongs to Group 1, and all Group 1 elements have one valence electron.

(iii) Sr belongs to Period 5, and thus, it has five shells.

(iv) K is a metal with electronic configuration 2, 8, 8, 1. Thus, it will donate its one electron to acquire the noble gas configuration.

(v) The atomic size increases down the group and decreases across a period. Rb is the element which has the largest atomic size.

(vi)  $\text{Be} < \text{Mg} < \text{Ca} < \text{Rb}$

**Marks: 3**

**Question 8.** Write three different chemical reactions showing the conversion of ethanoic acid to sodium ethanoate. Write balanced chemical equation in each case. Write the name of the reactants and the products other ethanoic acid and sodium ethanoate in each case.

**Solution:** Three different chemical reactions showing the conversion of ethanoic acid to sodium ethanoate:

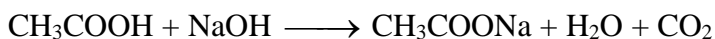
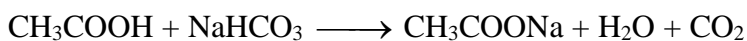
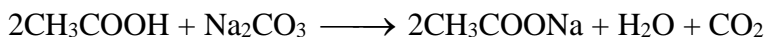

**Marks: 3**

**Question 9.** An element 'X' belong to 3<sup>rd</sup> period and group 13 of the Modern Periodic Table.

(a) Determine the valence electrons and the valency of 'X'.

(b) Molecular formula of the compound formed when 'X' reacts with an element 'Y' (atomic number = 8).

(c) Write the name and formula of the compound formed when 'X' combines with chlorine.

**Solution:** Period of X = 3

Group of X = 13

Atomic number of X = 13

Electronic configuration: 2, 8, 3

(a) Number of valence electrons = 3 and valency = 3

(b) Atomic number of Y = 8

Electronic configuration = 2, 6

Valency of Y = 2

Molecular formula of the compound formed when 'X' reacts with an element 'Y' is X<sub>2</sub>Y<sub>3</sub>.

(c) Atomic number of Cl = 17

Electronic configuration = 2, 8, 7

Valency of Y = 1

Molecular formula of the compound formed when 'X' reacts with an element 'Y' is XCl<sub>3</sub>.

**Marks: 3**

**Question 10.** An element 'X' has mass number 35 and number of neutrons 18. Write atomic number and electronic configuration of 'X'. Also write group number, period number and valency of 'X'.

**Solution:** Mass number of X = 35

Number of neutrons = 18

Atomic number = Mass number – Number of neutrons

= 35 – 18 = 17

Electronic configuration of X = 2, 8, 7

Group of X = 17

Period of X = 3

Valency of X = 1.

**Marks: 3**

**Question 11.** (a) List two reasons for the appearance of variations among the progeny formed by sexual reproduction.

(b)

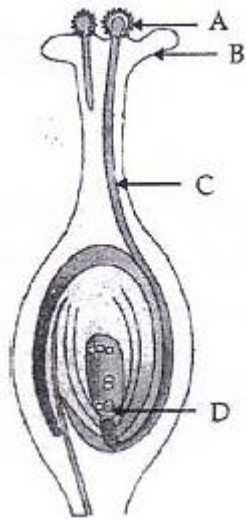

- (i) Name the part marked 'A' in the diagram.
- (ii) How does 'A' reach part 'B'?
- (iii) State the importance of the part 'C'.
- (iv) What happens to the part marked 'D' after fertilisation is over?

**Solution:** (a) Two reasons for the appearance of variations among the progeny formed by sexual reproduction are

1. Sexual reproduction results in new combinations of genes which are brought together during the formation of gametes.
2. Gene combinations are different in gametes.

- (b)
- (i) Part 'A' labelled is pollen grain.
  - (ii) Part 'B' is stigma. The pollen grain reaches the stigma during pollination.
  - (iii) Part 'C' is the pollen tube. The pollen tube carries the gametes to the embryo sac for fertilisation.
  - (iv) Part 'D' is the egg cell. After fertilisation with the male gametes, the egg cell forms the zygote.

**Marks: 3**

**Question 12.** Define reproduction. How does it help in providing stability to the population of species?

**Solution:** Reproduction is the ability of living organisms to produce living beings similar to them.

Reproduction maintains the number of chromosomes specific to a species in each generation. Multicellular organisms have specialised cells in their gonads, which have only half the number of chromosomes and half the amount of DNA as compared to non-reproductive body cells. So, when these germ cells from 2 different individuals combine during sexual reproduction to form a new individual, it results in the re-establishment of the number of chromosomes and the DNA content in the new generation. Thus, it provides stability to the population of a species.

**Marks: 3**

**Question 13.** Explain the term "Regeneration" as used in relation to reproduction of organisms. Describe briefly how regeneration is carried out in multicellular organisms like Hydra.

**Solution:** Regeneration is the ability of organisms to generate lost or damaged parts of the body.

When a hydra is bisected anywhere in the upper 7<sup>th</sup> or 8<sup>th</sup> part of the body column, the upper half will regenerate a foot at its basal end and the lower half will regenerate a head at its apical end; each half

generates the organ which it is missing. The regeneration is precise, and the head and foot are always formed specifically at the apical and basal ends, respectively.

**Marks: 3**

**Question 14.** “Two areas of study namely ‘evolution’ and ‘classification’ are interlinked”. Justify this statement.

**Solution:** All living things are identified and categorised on the basis of their body design in form and function. After a certain body design comes into existence, it will shape the effects of all other subsequent design changes simply because it already exists. So, characteristics which came into existence earlier are likely to be more basic than characteristics which have come into existence later. This means that the classification of life forms will be closely related to their evolution. On connecting this idea of evolution to classification, it is seen that some groups of organisms with ancient body designs have not changed very much. However, other groups of organisms have acquired their particular body designs relatively recently. Because there is a possibility that complexity in design will increase over evolutionary time, it may not be wrong to say that older organisms are simpler, while younger organisms are more complex.

**Marks: 3**

**Question 15.** How do Mendel’s experiment show that traits are inherited independently?

**Solution:** Mendel carried out dihybrid crosses by crossing two pea plants differing in contrasting traits of two characters. For example, he crossed a pea plant having yellow colour and round seed characters with another pea plant bearing green colour and wrinkled seed characters. In the F<sub>2</sub> generation, he obtained pea plants with two parental and two recombinant phenotypes as yellow round and green wrinkled (parental) and yellow wrinkled and green round (recombinant). This indicated that traits separated from their original parental combinations and got inherited independently.

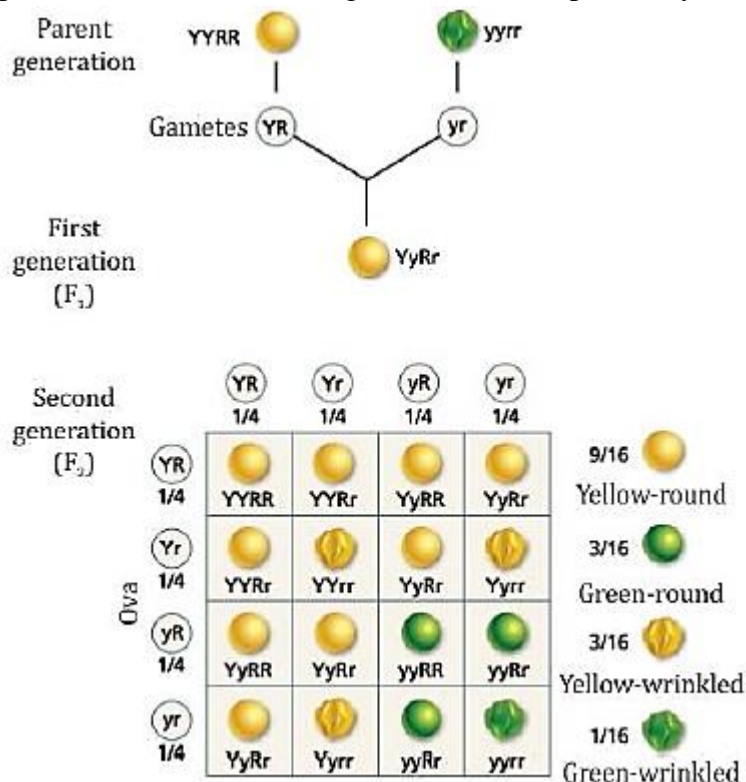

**Marks: 3**

**Question 16.** The activities of man had adverse effects on all forms of living organisms in the biosphere. Unlimited exploitation of nature by man disturbed the delicate ecological balance between the living and non-living components of the biosphere. The unfavourable conditions created by man himself threatened the survival not only of himself but also of the entire living organisms on the mother earth. One of your classmates is an active member of 'Eco club' of your school which is creating environmental awareness amongst the school students, spreading the same in the society and also working hard for preventing environmental degradation of the surroundings.

- (a) Why is it necessary to conserve our environment?  
 (b) State the importance of green and blue dust-bins in the safe disposal of the household waste.  
 (c) List two values exhibited by your classmate who is an active member of Eco-club of your school.

**Solution:** (a) It is necessary to conserve our environment because

- (i) It helps in protecting the ozone layer.  
 (ii) It helps in maintaining animal and human food chains.  
 (iii) It provides us with many useful products such as medicines and wood.  
 (b) Disposal of household waste is carried out in green and blue bins, respectively. It will be very useful in the separate disposal of biodegradable and non-biodegradable wastes. This will also ensure the application of 3Rs—reduce, reuse and recycle.  
 (c) Two values exhibited are  
 (i) Creating environmental awareness among students and society.  
 (ii) Working hard on prevention of environmental degradation of surroundings.

**Marks: 3**

**Question 17.** The image formed by a spherical mirror is real, inverted and is of magnification  $-2$ . If the image is at a distance of 30 cm from the mirror, where is the object placed? Find the focal length of the mirror. List two characteristics of the image formed if the object is moved 10 cm towards the mirror.

**Solution:** Given: Magnification,  $m = -2$

Distance of the image,  $v = -30$  cm

$$\text{Magnification, } m = -\frac{v}{u}$$

$$\therefore u = -\frac{v}{m} = -\frac{(-30)}{(-2)}$$

$$\therefore u = -15 \text{ cm}$$

Substituting these values in the mirror formula

$$\frac{1}{f} = \frac{1}{v} + \frac{1}{u}$$

$$= \frac{1}{(-30)} + \frac{1}{(-15)}$$

$$\frac{1}{f} = -\frac{1}{10}$$

$$\therefore f = -10 \text{ cm}$$

When the object is moved 10 cm towards the mirror the new position of the object is

$$u' = -(15 - 10) = -5 \text{ cm}$$

Substituting the new value in the mirror formula

$$\frac{1}{f} = \frac{1}{v} + \frac{1}{u'}$$

$$\frac{1}{v'} = \frac{1}{f} - \frac{1}{u'} = \frac{1}{10} - \frac{1}{(-5)}$$

$$\frac{1}{v'} = \frac{1}{10}$$

$$\therefore v' = 10 \text{ cm}$$

Thus, the image is located 10 cm behind the mirror.

$$\text{And magnification, } m' = -\frac{v'}{u'} = -\frac{10}{(-5)}$$

$$m' = 2$$

Since magnification is positive the image is erect and virtual.

Thus, the image is erect, virtual and magnified in nature.

**Marks: 3**

**Question 18.** Describe an activity to show that colours of white light splitted by a glass prism can be recombined to get white light by another identical glass prism. Also draw ray diagram to show the recombination of the spectrum of white light.

**Solution:** The seven colours of a spectrum can be recombined to give back white light as

1. Two identical glass prisms are placed such that their refracting surfaces are in opposite direction (placed inverted). When a beam of light is allowed to fall on the surface of one prism, a patch of ordinary white light is obtained on a screen placed behind the second prism.

2. The first prism disperses the white light into seven coloured rays. The second prism receives all the seven coloured rays from the first prism and recombines them into original white light. This is because the refraction produced by the second prism is equal and opposite to that produced by the first prism. Hence, the light coming out of the second prism will be white.

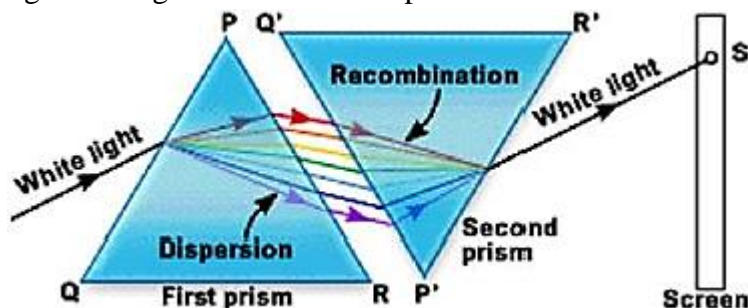

**Marks: 3**

**Question 19.** It is desired to obtain an erect image of an object, using concave mirror of focal length of 12 cm.

(i) What should be the range of distance of an object placed in front of the mirror?

(ii) Will the image be smaller or larger than the object? Draw ray diagram to show the formation of image in this case.

(iii) Where will the image of this object be, if it is placed 24 cm in front of the mirror? Draw ray diagram for this situation also justify your answer.

Show the positions of pole, principal focus and the centre of curvature in the above ray diagrams.

**Solution:** (i) To obtain an erect image, the object should be placed within the focus, i.e., between the pole and the focus. Here, the focal length of the mirror is 12 cm.

Hence, the object should be placed at a distance less than 12 cm.

(ii) The image will be larger than the object (enlarged).

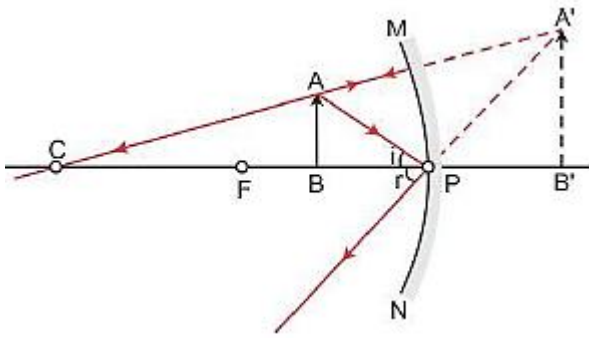

(iii) Since  $f = 12 \text{ cm} \rightarrow$  Centre of curvature  $= 2f = 24 \text{ cm}$

For an object placed at a distance 24 cm, i.e., at the centre of curvature of a concave mirror, the image formed will be real, inverted and of the same size as that of the object.

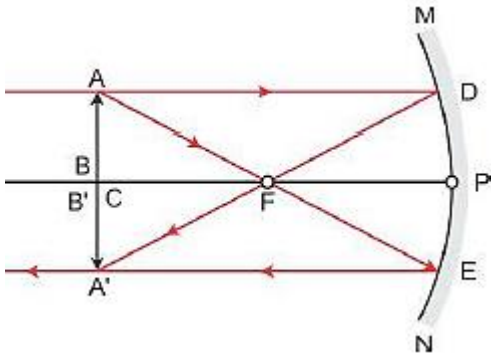

**Marks: 5**

**Question 20.** Define evolution. How does it occur? Describe how fossils provide us evidences in support of evolution.

**Solution:** Evolution is the formation of more complex organisms from pre-existing simpler organisms over a certain period. Accumulation of variation in genetic material forms the basis of evolutionary processes. Fossils provide a unique view into the history of life by showing the forms and features of life in the past. Fossils tell us how species have changed across long periods of the Earth's history.

Importance of fossils in the evolutionary process:

1. Some invertebrates living on the sea bed died and were buried in the sand.
2. More sand was accumulated and formed sandstone under pressure.
3. After millions of years, dinosaurs living in the area died and their bodies were buried in the mud.
4. The mud got compressed into the rock, just above the rock containing earlier invertebrate fossils.
5. Again millions of years later, the bodies of horse-like creatures dying in the area were fossilised in the rocks above the earlier rocks.
6. Much later, because of erosion and water flow, some rocks wore out and exposed the horse-like fossils.

**Marks: 5**

**Question 21.** What is placenta? Describe its structure. State its functions in case of a pregnant human female.

**Solution:** The placenta is an organ attached to the lining of the womb during pregnancy. The placenta is composed of both maternal tissue and tissue derived from the embryo. It contains blood spaces on the mother's side and villi on the embryo's side.

Functions of the placenta:

1. It provides food and oxygen to the foetus.



2. The foetus gives away waste products and carbon dioxide to the mother's blood for excretion.

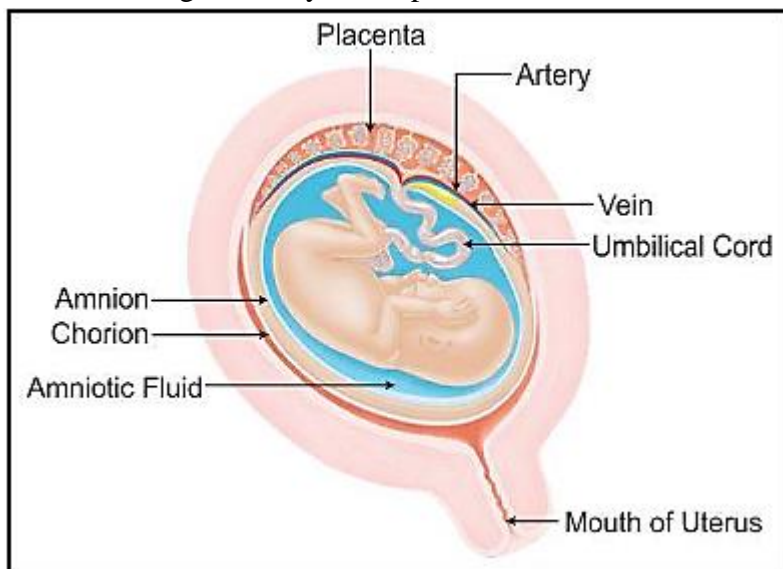

**Marks: 5**

**Question 22.** A carbon compound 'P' on heating with excess conc.  $\text{H}_2\text{SO}_4$  forms another carbon compound 'Q' which on addition of hydrogen in the presence of nickel catalyst forms a saturated carbon compound 'R'. One molecule of 'R' on combustion forms two molecules of carbon dioxide and three molecules of water. Identify P, Q and R and write chemical equations for the reactions involved.

**Solution:**  $\text{P} \xrightarrow{\text{Excess H}_2\text{SO}_4} \text{Q} \xrightarrow{\text{H}_2/\text{Nickel catalyst}} \text{R} \xrightarrow{\text{O}_2} 2\text{CO}_2 + 3\text{H}_2\text{O}$

$\text{P} \xrightarrow{\text{Excess H}_2\text{SO}_4} \text{Q}$

$\text{CH}_3\text{CH}_2\text{OH} \xrightarrow{\text{Excess H}_2\text{SO}_4} \text{CH}_2 = \text{CH}_2$

$\text{Q} \xrightarrow{\text{H}_2/\text{Nickel catalyst}} \text{R}$

$\text{CH}_2 = \text{CH}_2 \xrightarrow{\text{H}_2/\text{Nickel catalyst}} \text{CH}_3 - \text{CH}_3$

$\text{R} \xrightarrow{\text{O}_2} 2\text{CO}_2 + 3\text{H}_2\text{O}$

$\text{CH}_3 - \text{CH}_3 \xrightarrow{\text{O}_2} 2\text{CO}_2 + 3\text{H}_2\text{O}$

$\text{CH}_3\text{CH}_2\text{OH} \xrightarrow{\text{Excess H}_2\text{SO}_4} \text{CH}_2 = \text{CH}_2 \xrightarrow{\text{H}_2/\text{Nickel catalyst}} \text{CH}_3 - \text{CH}_3 \xrightarrow{\text{O}_2} 2\text{CO}_2 + 3\text{H}_2\text{O}$

P	Q	R
Ethanol	Ethene	Ethane

**Marks: 5**

**Question 23.** What is atmospheric refraction? Use this phenomenon to explain the following natural events:

- (a) Twinkling of stars
- (b) Advanced sun-rise and delayed sun-set.

Draw diagrams to illustrate your answers.

**Solution:** (a) Stars emit light on their own; when this light travels through the Earth's atmosphere which has variable optical density, the continuously changing atmosphere refracts the light from the stars in different amounts from one moment to the next. The light seems to be bright and dim as it keeps changing because of continuous refraction through the different layers of the atmosphere of the Earth. Hence, we say light twinkles at night.

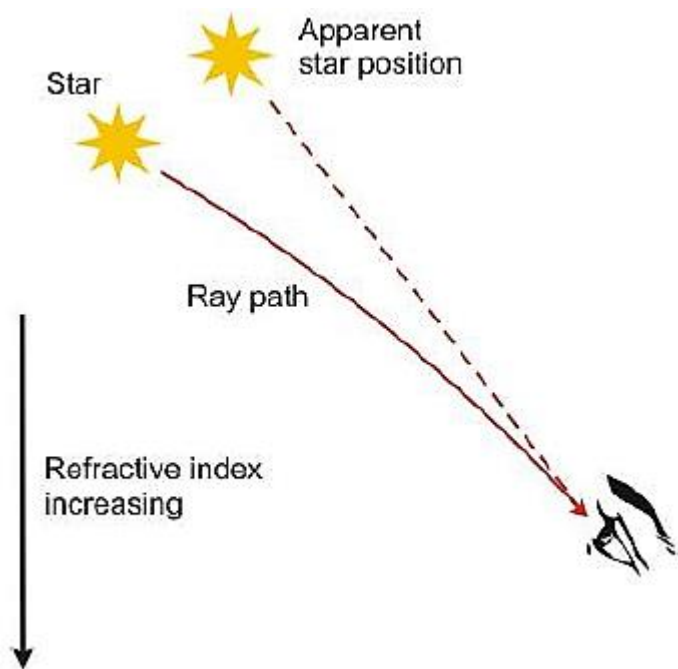

(b) The sunrise is advanced because of the atmospheric refraction of sunlight. An observer on the Earth sees the Sun two minutes before the Sun reaches the horizon. A ray of sunlight entering the Earth's atmosphere follows a curved path because of atmospheric refraction before reaching the Earth. This happens because of a gradual variation in the refractive index of the atmosphere. For an observer on the Earth, the apparent position of the Sun is slightly higher than the actual position. Hence, the Sun is seen before it reaches the horizon.

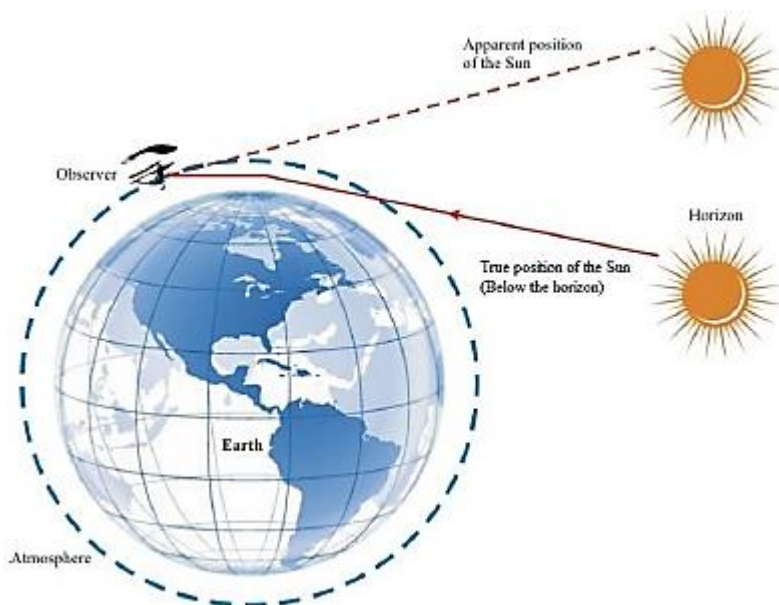

The increased atmospheric refraction of sunlight occurs also at sunset. In this case, the observer on the Earth continues to see the setting Sun for two minutes after the Sun has dipped below the horizon, thus delaying the sunset. The advanced sunrise and delayed sunset increase the duration of the day by four minutes.

**Marks: 5**

**Question 24.** (a) Define focal length of a divergent lens.

(b) A divergent lens of focal length 30 cm forms the image of an object of size 6 cm on the same side as the object at a distance of 15 cm from its optical center. Use lens formula to determine the distance of the object from the lens and the size of the image formed.

(c) Draw a ray diagram to show the formation of image in the above situation.

**Solution:** (a) The focal length of a diverging lens is half the value of its radius of curvature. Conventionally, the sign of the focal length of the diverging lens is taken as negative.

(b) Given:

$f = -20$  cm (It is a diverging lens.)

$v = -15$  cm (Image is formed on the same side of the lens.)

Using the lens formula,

$$\frac{1}{f} = \frac{1}{v} - \frac{1}{u}$$

$$\Rightarrow \frac{1}{u} = \frac{1}{v} + \frac{1}{f}$$

$$= \frac{1}{(-15)} + \frac{1}{(-20)} = -\frac{1}{30}$$

$$\therefore u = -30 \text{ cm}$$

Given: Height of the object,  $h = 6$  cm

Height of the image,  $h' = ?$

$$\text{Magnification, } m = \frac{v}{u} = \frac{h'}{h}$$

$$\therefore h' = h \frac{v}{u} = 6 \times \frac{(-15)}{(-30)}$$

$$\therefore h' = 3 \text{ cm}$$

(c)

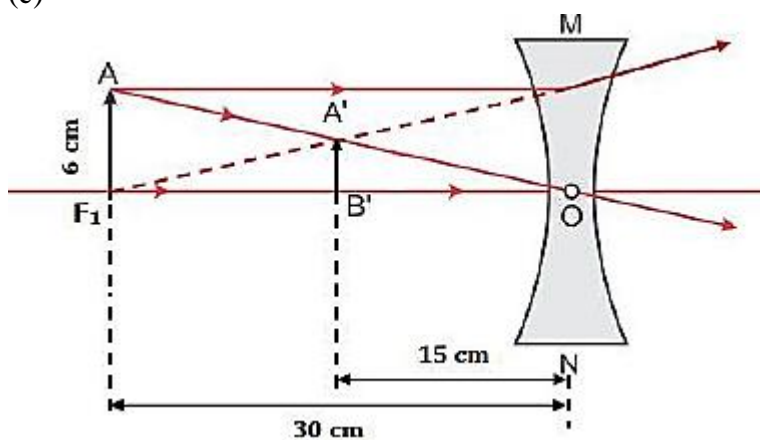

Marks: 5

## SECTION B

**Question 25.** A student while observing an embryo of a pea seed in the laboratory listed various parts of the embryo as given below:

*Testa, Tegmen, Radicle, Plumule, Micropyle, Cotyledon.*

On examining the list the teacher remarked that only three parts are correct.

Select three correct parts from the above list:

- (a) Testa, Radicle, Cotyledon
- (b) Tegmen, Radicle, Micropyle
- (c) Cotyledon, Plumule, Testa

(d) Radicle, Cotyledon, Plumule

**Solution:** (d) Radicle, Cotyledon, Plumule

A dicot embryo consists of radicle, plumule and a pair of cotyledons. Testa, tegmen and micropyle are the parts of the seed coat.

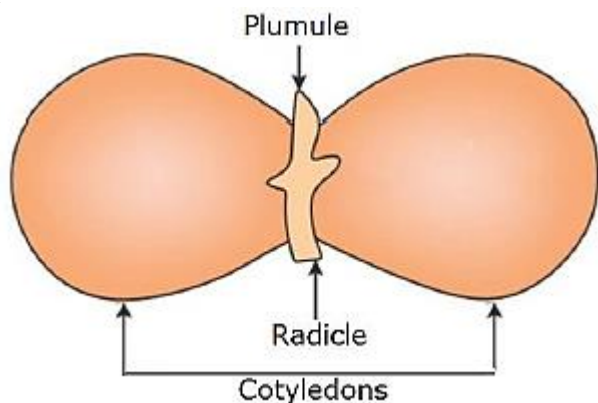

**Marks: 1**

**Question 26.** If you are asked to select a group of two vegetables, out of the following, having homologous structures which one would you select?

- (a) Carrot and radish
- (b) Potato and sweet potato
- (c) Potato and tomato
- (d) Lady finger and potato

**Solution:** (a) Carrot and radish

Homologous structures are fundamentally same in structure and origin but are modified to perform different functions in different organisms. They indicate common ancestry. From the given plants, carrot and radish are homologous structures because they both are underground roots. While potato is a stem, sweet potato is a root, tomato is a fruit and lady finger is a vegetable.

**Marks: 1**

**Question 27.** In the following ray diagram the correctly marked angle are:

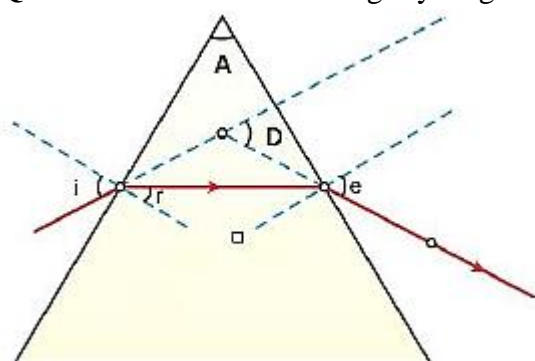

- (a)  $\angle i$  and  $\angle e$
- (b)  $\angle A$  and  $\angle D$
- (c)  $\angle i$ ,  $\angle e$  and  $\angle D$
- (d)  $\angle r$ ,  $\angle A$  and  $\angle D$

**Solution:** (d)  $\angle r$ ,  $\angle A$  and  $\angle D$

The angle between the normal and the incident ray is the angle of incidence.

The angle between the normal and the emergent ray is the angle of emergence.

The correctly marked angles are shown in the diagram below:

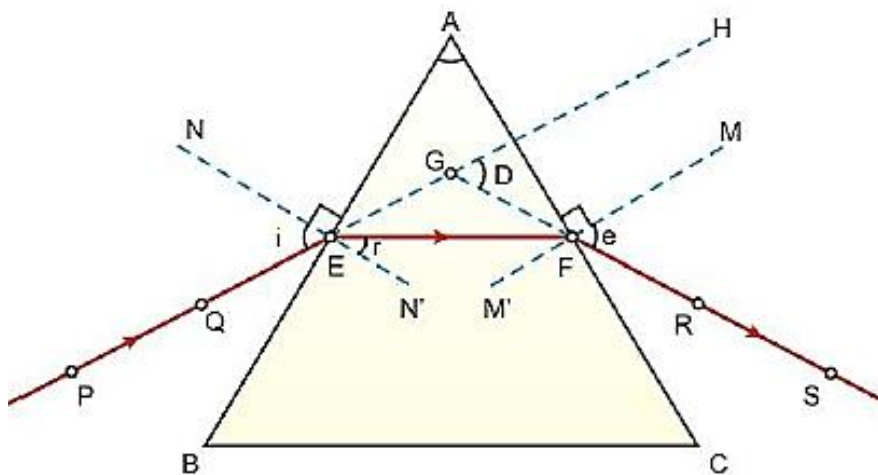

**Marks: 1**

**Question 28.** In your laboratory you trace the path of light rays through a glass slab for different values of angle of incidence ( $\angle i$ ) and in each case measure the values of the corresponding angle of refraction ( $\angle r$ ) and angle of emergence ( $\angle e$ ). On the basis of your observations your correct conclusion is:

- (a)  $\angle i$  is more than  $\angle r$ , but nearly equal to  $\angle e$
- (b)  $\angle i$  is less than  $\angle r$ , but nearly equal to  $\angle e$
- (c)  $\angle i$  is more than  $\angle e$ , but nearly equal to  $\angle r$
- (d)  $\angle i$  is less than  $\angle e$ , but nearly equal to  $\angle r$

**Solution:** (a)  $\angle i$  is more than  $\angle r$ , but nearly equal to  $\angle e$

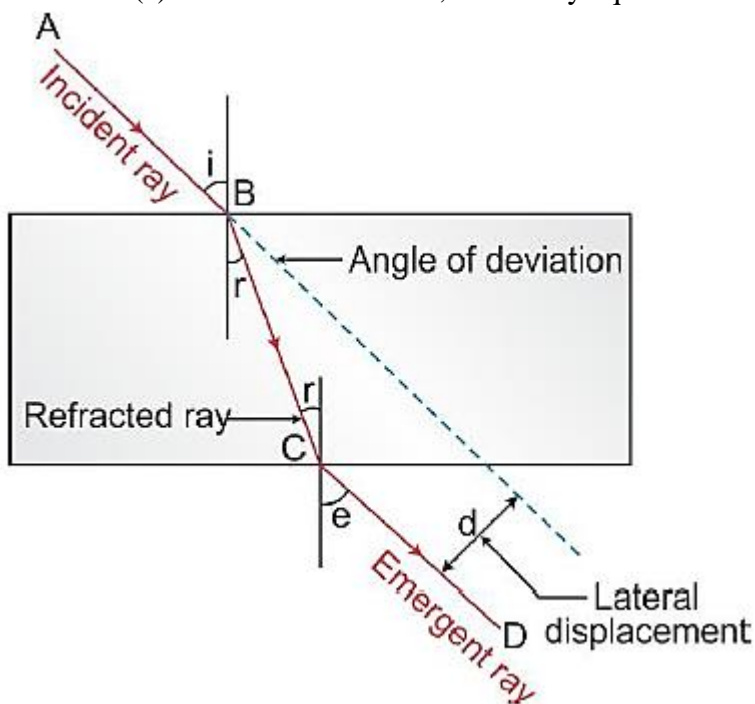

On entering a glass slab, the incident light gets refracted. According to Snell's law, we get

$$\mu = \frac{\sin i}{\sin r}$$

For glass  $\mu > 1$

$$\therefore \sin r < \sin i$$

$$\text{or } r < i$$

In refraction of light through a glass slab, the emergent ray is parallel to the incident ray. Thus,  $\angle i = \angle e$ .

**Marks: 1**

**Question 29.** To determine the approximate value of the focal length of a given concave mirror, you focus the image of a distant object formed by the mirror on a screen. The image obtained on the screen, as compared to the object is always:

- (a) Laterally inverted and diminished
- (b) Inverted and diminished
- (c) Erect and diminished
- (d) Erect and highly diminished

**Solution:** (b) inverted and diminished

Images obtained on the screen are always diminished and inverted in nature.

**Marks: 1**

**Question 30.** Suppose you have focused on a screen the image of candle flame placed at the farthest end of the laboratory table using a convex lens. If your teacher suggests you to focus the parallel rays of the sun, reaching your laboratory table, on the same screen, what you are expected to do is to move the:

- (a) lens slightly towards the screen
- (b) lens slightly away from the screen
- (c) lens slightly towards the sun
- (d) lens and screen both towards the sun

**Solution:** (a) lens slightly towards the screen

To focus the parallel rays of the Sun, the lens should be slightly moved towards the screen.

**Marks: 1**

**Question 31.** For preparing soap in the laboratory we require an oil and a base. Which of the following combinations of an oil and a base would be best suited for the preparation of soap?

- (a) Castor oil and calcium hydroxide
- (b) Turpentine oil and sodium hydroxide
- (c) Castor oil and sodium hydroxide
- (d) Mustard oil and calcium hydroxide

**Solution:** (c) P and Q

Dissolving chloride salts of calcium or magnesium in distilled water will make the water hard and lather formation will take place with difficulty.

**Marks: 1**

**Question 32.** A student puts a drop of reaction mixture of a saponification reaction first a blue litmus paper and then on a red litmus paper. He may observe that:

- (a) There is no change in the blue litmus paper and the red litmus paper turns white.
- (b) There is no change in the red litmus paper and the blue litmus paper turns red.
- (c) There is no change in the blue litmus paper and the red litmus paper turns blue.
- (d) No change in colour is observed in both the litmus papers.

**Solution:** (c)

The molecules of soap are sodium or potassium salts of long chain carboxylic acids. So, when a student puts a drop of reaction mixture of a saponification reaction first on a blue litmus paper and then on a red litmus paper, he will observe that there is no change in the blue litmus paper and the red litmus paper turns blue.

**Marks: 1**

**Question 33.** In the neighbourhood of your school, hard water required for an experiment is not available. Select from the following group of salts available in your school, a group each member of which, if dissolved in distilled water, will make it hard:

- (a) Sodium chloride, calcium chloride
- (b) Potassium chloride, sodium chloride
- (c) Sodium chloride, magnesium chloride
- (d) Calcium chloride, magnesium chloride

**Solution:** (d) Calcium chloride, magnesium chloride

Dissolving chloride salts of calcium or magnesium in distilled water will make the water hard, and lather formation will take place with difficulty.

**Marks: 1**

**Question 34.** A student is observing a permanent slide showing sequentially the different stages of asexual reproduction taking place in yeast. Name this process and draw diagrams, of what he observes, in a proper sequence.

**Solution:** Yeast reproduces asexually by the process of budding. Different stages of budding as observed by the student are depicted below:

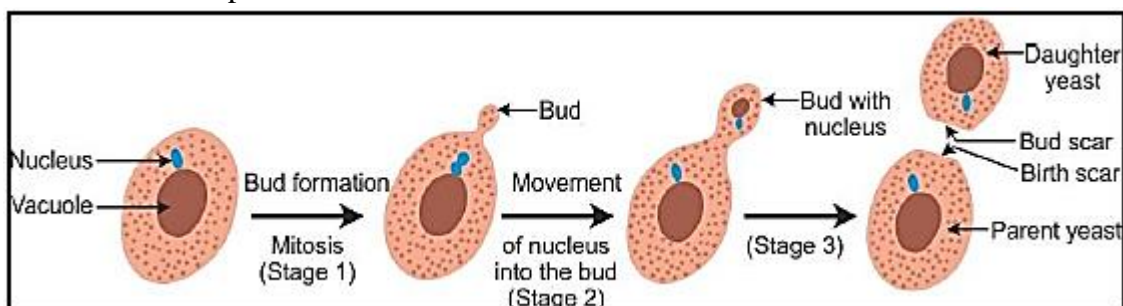

**Marks: 2**

**Question 35.** An object of height 2.5 cm is placed at a distance of 15 cm from the optical centre 'O' of a convex lens of focal length 10 cm. Draw a ray diagram to find the position and size of the image formed. Mark optical 'O', principal focus F and height of the image on the diagram.

**Solution:** Ray diagram:

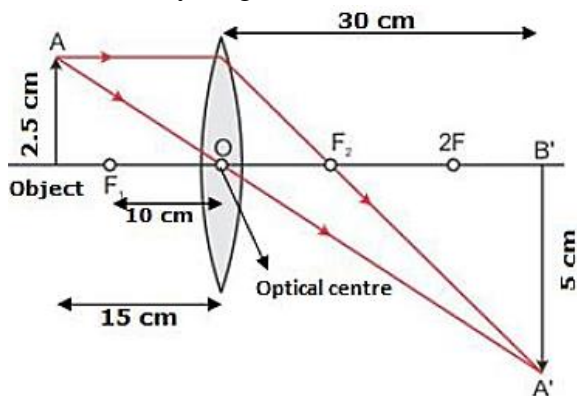

**Marks: 2**

**Question 36.** A student adds a spoon full of powdered sodium hydrogen carbonate to a flask containing ethanoic acid. List two main observations, he must note in his note book, about the reaction that takes place. Also write chemical equation for the reaction.

**Solution:** Two main observations about the reaction:

- (i) Brisk effervescence of carbon dioxide which turns lime water milky.
- (ii) It is a neutralisation reaction and heat is released.

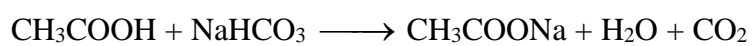

**Marks: 2**